

- 1 Contents
- 2 About
- 3 Editorial Board – Technical Support
- 4 Information for Peers – Guiding Principles
- # Electrical Engineering – Théorie
- 355 Thoughts on the Possibility of Damage of High-Voltage Electrical Insulation below the So-Called Inception Voltage: A Proposed Solution and Some Further Comments – Part II  
Hui Fan, Jialei Hu, Yi Yin, M.G. Danikas
- # Telecommunications Engineering – Théorie
- 369 Transmission Lines: A Precise Formulation within the Distributed Circuit Model with an Application to Nominal Values without Tolerance in Technical Data Sheets and Cable Specifications (Postponed)  
N.I. Yannopoulou, P.E. Zimourtopoulos



*This small European Journal is  
In the Defense of Honesty in Science and Ethics in Engineering*

**Publisher** – otoiser—open transactions on independent scientific engineering research, [www.otoiser.org](http://www.otoiser.org)–[info@otoiser.org](mailto:info@otoiser.org): Hauptstraße 52, 2831 Scheiblingkirchen, Austria

**Language** – We emphasize the origins of the Journal by using English, German and French, as well as, a Hellenic vignette in the cover page. However, since we recognize the dominance of US English in the technical literature, we adopted it as the Journal's language, although it is not our native language.

**Focus** – We consider Radio–FUNK, which still creates a vivid impression of the untouchable, and its Technology–TECHNIK, from an Advanced–PLUS point of view, Plus–PLUS Telecommunications Engineering, Electrical Engineering and Computer Science, that is, we dynamically focus at any related scientific-engineering research regarding Théorie, Expérimentation, Métrologie, Logiciel, ou Applications.

**Scope** – We emphasize this scope broadness by extending the title of the Journal with a Doppelkreuz-Zeichen # which we use as a placeholder for substitution of our Editorial Team disciplines: # Telecommunications etc. as above, or # High Voltage, # Software Engineering, # Simulation etc. as below.

**Frequency** – We publish 3 issues per year: on 31st of January, on 31st of May, and on 30th of September, as well as, an extra issue every 3 papers and a volume every 2 years.

**Editions** – We increase the edition number of an issue only when is needed to reform one or more of its papers—thus to increase their version numbers—but we keep unchanged its 1st edition date shown on its front page and we number its pages sequentially from 1. We count the editions of *About* separately.

**Format** – We use a fixed-space font, hyphenation, justification, unfixed word spacing, and the uncommon for Journals A5 (half A4) page size to achieve WYSIWYG printing and clear reading of 2 to 4 side-by-side pages on wide-screen displays.

**Printing-on-Demand** – We can email gratis PDF files at 300–4000 dpi in booklet page scaling of brochure and book type.

**Copyright** – We publish under a Creative Commons Attribution, CC-BY 3.0 Unported or CC-BY 4.0 International, License only.

Please download the latest *About* edition from  
<http://about.ftpj.otoiser.org>

**Editorial Team****# Electrical Engineering**

Professor Michael Danikas, mdanikas@ee.duth.gr  
EECE, Democritus University of Thrace, Greece

**# High Voltage Engineering # Insulating Materials**

Assistant Professor Athanasios Karlis, akarlis@ee.duth.gr  
EECE, Democritus University of Thrace, Greece

**# Electrical Machines # Renewable Energies # Electric Vehicles****# Computer Science**

Professor Vasilis Katos, vkatos@bournemouth.ac.uk  
Head of Computer and Informatics Dept, Bournemouth Univ, UK

**# Computer Engineering # Software Engineering # Cyber Security**

Lecturer Sotirios Kontogiannis, skontog@gmail.com  
Business Administration Dept, TEI, Western Macedonia, Greece

**# Internet Engineering # Learning Management Systems**

Dr. Apostolos Syropoulos, asyropoulos@yahoo.com  
BSc-Physics, MSc-Computer Science, PhD-Computer Science  
Independent Researcher, Xanthi, Greece

**# Hypercomputation # Fuzzy Computation # Digital Typography****# Telecommunications Engineering**

Dr. Nikolaos Berketis, nberketis@gmail.com  
BSc-Mathematics, MSc-Applied Maths, PhD-Applied Mathematics  
Independent Researcher, Athens, Greece

**# Applied EM Electromagnetics # Applied Mathematics**

Dr. Nikolitsa Yannopoulou, yin@arg.op4.eu [\*]  
Diploma Eng-EE, MEng-Telecom-EECE, PhD-Eng-Antennas-EECE  
Independent Researcher, Scheiblingkirchen, Austria

Dr. Petros Zimourtopoulos, pez@arg.op4.eu [\*]  
BSc-Physics, MSc-Radio-Electronics, PhD-Antennas-EE  
Independent Researcher, Scheiblingkirchen, Austria

**# Antennas # Metrology # EM Software # Simulation # Virtual Labs****# Applied EM # Education # FLOSS # Amateur Radio # Electronics****\* Copy and Layout Editing, Proof Reading, Issue and Website Management, Paper and About Reprints, Volumes and Web Pages****Technical Support**

Konstantinos Kondylis, kkondylis@gmail.com  
Diploma Eng-EECE, MEng-Telecom-EECE, Doha, Qatar  
Christos Koutsos, ckoutsos@gmail.com  
Diploma Eng-EECE, MEng-Telecom-EECE, Bratislava, SK

**Information for Authors**

This is a small, but independent, low profile Journal, in which we are all—Authors, Reviewers, Readers, and Editors—free at last to be Peers in Knowledge, without suffering from Journal roles or positions, Professional–Amateur–Academic statuses, or established "impact factorizations", under the following guiding principles:

**Authors** – We know what Work means, we respect the Work of the Independent Researcher in Science and Engineering and we want to exhibit his Work. Thus, we decided to found this Free and Open Access Journal in which to publish this Work. Furthermore, as we care indeed for the Work of the technical author—especially a young or a beginner one—we strongly support the publication of his Work, as follows:

- 1 We do not demand from the author to transfer his own copyright to us. Instead, we only consider papers resulting from original research work only, and only if the author can assure us that he owns the copyright of his own paper as well as that he submits to the Journal either an original copy or a revised version of his own paper, for possible publication after review—or even for immediate republication, if this paper has already been published after review—but, in any case under a Creative Commons Attribution, CC-BY 3 Unported or CC-BY 4 International, License, only.
- 2 We encourage the author to submit his own paper written just in Basic English plus Technical Terminology.
- 3 We encourage the author even to select a pen name, which may drop it at any time to reveal his identity.
- 4 We encourage the author to submit an accepted for publication paper, which he was forced to decline that publication because it would be based on a review with unacceptable evaluation or derogatory comments.
- 5 We encourage the author to submit any paper that was rejected after a poor, impotent, inadequate, unreasonable, irresponsible, incompetent, or "just ticking" review.
- 6 We encourage the author to submit an unreviewed paper of his own that he uploaded on some Open Access repository.
- 7 We encourage the author to upload his published paper in our Journal to at least one Truly Free Open Repository, e.g. such as <http://viXra.org> and <https://archive.org>.

- 8 We provide the author with the ability to update, at any time, the reference links of his paper.
- 9 We provide the author with a decent, express, peer review process, of up to just 4 weeks, by at least 2, either anonymous or onymous, reviewers.
- 10 We provide the author with the option to choose from 2 review processes: the traditional, anonymous, close one, as well as, a contemporary, onymous, open review in our private mailing list for Peer Discussion.
- 11 Under the Clause 1 : We immediately accept for publication a research paper directly resulting from a Project Report, or a Diploma-, Master-, or PhD-thesis, which already the author has successfully defended before a committee of experts, as long as he can mention 2 members of this committee who approved his Work.
- 12 Under the Clause 1 : We immediately accept for publication any paper which is not Openly Accessible on the Internet.
- 13 We immediately publish online a paper, as soon as it is accepted for publication in the Journal.
- 14 We quickly publish an extra issue—that is in excess of the 3 issues we publish a year—as soon as the review process of 3 papers is completed.

**Reviewers** – Every peer may voluntarily become a reviewer of the Journal in his skillfulness for as long as he wishes. In addition, each author of the Journal must review one paper in his expertness for each one of his published papers.

**Readers** – Every reader is a potential post-reviewer: we welcome comments and post-reviews in our private mailing list for Peer Discussion.

**Editors** – Every editor owns a PhD degree—to objectively prove that he really has the working experience of passing through the dominant publishing system. An editor pre-reviews a paper in order to check its compliance to our guiding principles and to select the appropriate reviewers of it. We can accept for consideration papers only in the expertise areas currently shown in the Editorial Team page, above. However, since we are very willing to amplify and extend the Scope of the Journal, we welcome the volunteer expert, in any related subject, who wants to join the Editorial Team as long as he unreservedly accepts our guiding principles.

## Electronic Publishing

We regularly use the Free Libre Open Source Software Libre Office with the Free Liberation Mono font and the Freewares PDFCreator and PDF-Xchange Viewer. We also use, with some basic html code of ours: the Free Open Source Software Open Journal System OJS by the Public Knowledge Project PKP installed in our website, and the Free Open Digital Library of Internet Archive website, where we upload the FTP#J Collection of Issues, Paper reprints, *About* documents, and Volumes, in both portrait and landscape orientations, for download or very clear online reading with the Free Open Source BookReader.

## Submissions

We can only consider papers written in the preferable and recommended odt format of LibreOffice, or even a paper in the MS Office with MathType doc format, if it would be proved that it is fully compatible with LibreOffice indeed.

**Legal Notice** – It is taken for granted that the submitter–correspondent author accepts, without any reservation, the totality of our publication conditions as they are analytically detailed here, in this *About*, as well as, that he also carries, in the case of a paper by multiple authors, the independent will of each one of his co-authors to unreservedly accept all the aforementioned conditions for their paper.

## Internet Addresses

**Submissions** : sub@ftpj.otoiser.org

**Send Updates** : updates@ftpj.otoiser.org

**Printing-on-Demand** : pod@ftpj.otoiser.org

**Technical Support TS** : technical-support@ftpj.otoiser.org

**Principal Contact** : principal-contact@ftpj.otoiser.org

**Peer Discussion List** : www.peers.ftpj.otoiser.org

**Editorial Team & TS List** : www.etts.ftpj.otoiser.org

**The FTP#J Collection at Internet Archive Digital Library** :  
<https://archive.org/details/@funktechnikplusjournal>

**Sample Paper Templates** : www.template.ftpj.otoiser.org

**Reference Link Updates** : www.updates.ftpj.otoiser.org

**Internet Publishing** : www.ftpj.otoiser.org

---

*This document is licensed under a Creative Commons Attribution 4.0 International License – <https://creativecommons.org/licenses/by/4.0>*

# Thoughts on the Possibility of Damage of High-Voltage Electrical Insulation below the So-Called Inception Voltage: A Proposed Solution and Some Further Comments - Part II

Hui Fan, Jialei Hu, Yi Yin, M.G. Danikas \*

- [1] State Grid Hebei Electric Power Research Institute, Hebei, People's Republic of China
- [2, 3] Department of Electrical Engineering, Shanghai Jiao Tong University, Shanghai, People's Republic of China
- [4] Department of Electrical and Computer Engineering, Power Systems Laboratory, Democritus University of Thrace, Xanthi, Greece

## Abstract

An interesting event reported long time ago, namely that charging phenomena may happen below inception voltage, is further discussed in the present paper. A previous paper in this journal referred to the historical background of the research on this phenomenon and also to the relevant equations governing it. As was pointed out, differential equations are used in order to correctly approach the charging events below inception voltage.

In the present paper, an iterative method and the finite element method are used to establish an algorithm with two loops. A typical case is studied, where a solid sheet insulation contains a void. The inception voltage is calculated by the proposed algorithm under the typical case for both AC and DC voltage.

## Keywords

Partial discharges, charging phenomena below inception voltage, high voltage insulation, cavities, inception voltage, simulation

## Introduction

In electrical engineering, partial discharge (PD) is a localized dielectric breakdown of a small portion of a solid or fluid electrical insulation system under high voltage stress, which does not bridge the space between two conductors. PD can occur in a gaseous, liquid or solid insulating medium. It often starts within gas voids, such as voids, for example, in solid epoxy insulation or bubbles in transformer oil. Protracted partial discharge can erode solid insulation and eventually lead to breakdown of insulation [1].

Discharge inception voltage (DIV) is such a voltage, above which, partial discharge (PD) occurs. When measuring DIV by experiments, a PD detection system is used. As the voltage applied on the insulating samples increases, PD detection begins to register PD signals, and that is the so-called DIV.

Then the question comes whether the so-called DIV is the real DIV. Due to background interference or the limitation of equipment sensitivity, it is possible that PD happens below the so-called IV and the detection equipment cannot detect or recognize these PD signals. To put it another way, there may be charging phenomena that can

go undetected by a PD detection system. In other words, it is difficult to ensure that there is no PD (or charging phenomena) below the so-called DIV. Detection of PD or not depends on the sensitivity of the PD detection system. Under these circumstances, PD (or charging phenomena) may happen and the insulations may be damaged to some extent, when they are below the so-called DIV. Sudden insulation damages have been reported in [2]. In [2] was also reported that sub-corona current in a polymer cavity with an applied voltage below DIV can cause cavity surface chemical changes that are similar to changes that occur when polymer insulation fails under full corona. Furthermore, a previous publication in this journal [3], proposed an approach to the subject of charging phenomena below inception voltage which is to calculate DIV by solving differential equations.

When investigating the discharge mechanism in insulation with voids, many researchers have a similar approach. The cavity will discharge when the voltage across the cavity attains its breakdown value [4]. Based on such mechanism, many researchers calculate the DIV. Expressions are derived for the discharge inception voltage, at which discharges

occur in enclosed voids within the insulation of single-core [5] and three-core [6] cables. In reference [7], researchers report a technique for estimating the DIV in case of discharges occurring in voids in solid sheet insulation in the ambient medium of air.

However, these approaches present two problems. One is the necessary of analytical solution. The details of voids and defects are ignored to a certain extent, thus the equations are solved in an analytical way. When there is no analytical solution, these approaches fail. The other one is that the material parameters must be linear. In cross-linked polyethylene (XLPE), for example, such conditions are usually not met. To overcome these two problems, in this paper, iterative method and finite element method (FEM) are used to establish an algorithm with two loops. A typical case is studied, where a solid sheet insulation contains a void. The DIV is calculated by the proposed algorithm under the typical case in both AC and DC voltage.

## Algorithms

### 1. Outer Loop

Partial discharges within a solid insulating material are usually initiated within

gas-filled voids. If the voltage stress across the void is increased above the strength of the gas within the void, PD activity will start within the void. For insulating samples with voids, DIV is such a voltage, at which, the maximum electric field in voids equals the local breakdown field strength.

When details of voids and nonlinearity of material parameters are considered, there is no analytical solution. As a result, it is difficult to calculate voltage from electric field directly. In this case, the procedure may be as follows.

First, let's consider a problem in Fig. 1(a) with analytical solution, and a similar problem in Fig. 1(b) without analytical solution.

Problem (a) is a plate capacitor, the electric field intensity  $E = U/L$ . This means we can calculate electric field by voltage. Also, we can have  $U = E \cdot L$ . That means, that it is possible to calculate voltage from the electric field. Problem (b) presents a similar problem, but without analytical solution. This means we cannot have an expression to describe the relation between  $E$  and  $U$  directly. In the present paper, it is obvious that the problem is also without analytical solution.

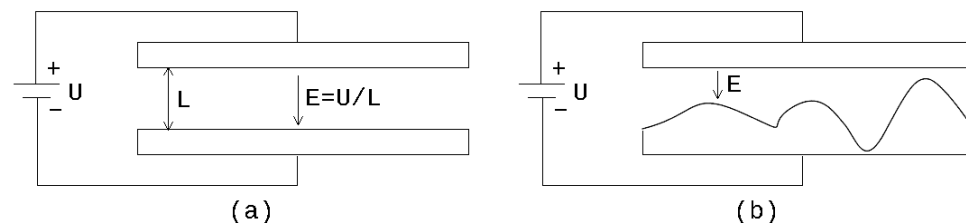

Fig. 1: (a) Geometry that can be approached by analytical solution, (b) Geometry that cannot have an analytical solution

To solve such a problem, FEM is a common method. In mathematics, FEM can solve partial differential equations under boundary conditions. Voltage is a kind of boundary condition. That means if the voltage is given, the boundary conditions are known and the FEM problem can be solved. So, when we use FEM, the electric field may be calculated from the given voltage.

In conclusion, one may say that by numerical calculation of electromagnetic fields, when the voltage is viewed as a kind of boundary condition, it is possible to calculate the electric field from the voltage. We can select voltage and calculate field by this voltage. If the field calculated equals to the local breakdown field strength, the voltage assumed is the solution. Thus, an iterative method is suggested, where by continuous trials and adjustments a solution can be found.

Consequently the steps followed are given below:

Step 1: Guess a voltage and apply it on the insulating sample.

Step 2: Calculate the electric field from voltage (discussed later in the inner loop). Subsequently, we have the maximum electric field in voids under this voltage.

Step 3: If the maximum electric field equals the breakdown field strength, this is the DIV we want. If not, guess another voltage, and go back to step 2.

This procedure is a loop, and the computational efficiency is influenced by the way we guess voltage in step 3. It is clear that the voltage and the electric field are positively correlated. In other words, the electric field increases when the voltage is higher. That gives a

consistent principle that if we want to have a higher electric field in step 2, we must guess a higher voltage in step 3, and vice versa. By this principle, we may solve the outer loop fast.

## 2. Inner Loop

Having in mind the non-linearity of material parameters, the equations used are as

$$E = -\nabla V \quad (1)$$

$$J = \begin{cases} sE & \text{DC} \\ (s + j\omega\epsilon)E & \text{AC} \end{cases} \quad (2)$$

$$\nabla \cdot J = 0 \quad (3)$$

where,  $E$  is the electric field intensity,  $V$  is the voltage,  $s$  is the electrical conductivity,  $\omega$  is the angular frequency of the voltage applied,  $\epsilon$  is the dielectric constant,  $J$  is the electric current density,  $j$  is the imaginary unit. In the AC case, the angular frequency is set here as  $100\pi$  rad/s.

Eq. (1) is the definition of voltage. Eq. (2) is the constitutive equation, which describes the relation between the current and the electric field. Eq. (3) is the current conservation equation. When we substitute Eqs. (1) and (2) into Eq. (3), we will have Bruning's quasi-steady

equation for current flow, which has been discussed in our previous publication in this journal [3].

In Eq. (2), the electrical conductivity  $s$  is influenced by the electric field intensity  $E$ , as Eq. (4) shows

$$s = s(E) \quad (4)$$

Although conductivity depends on both temperature and electric field according to [10], in the present case temperature does not change and the conductivity is determined by the electric field. Consequently, eq. (4) is used. Such phenomena have been reported and measured in [8] in XLPE. High field conductivity is a nonlinear variable under different electric fields. That causes the difficulty when we use traditional FEM to solve these equations.

Consequently an iterative method is used whose procedure is as follows:

Step 1: Guess a voltage distribution.

Step 2: Calculate material parameters by equation (4) based on the voltage distribution.

Step 3: Treat material parameters as constants and solve equations (1) to (3) by tradi-

tional FEM (discussed later). Thus we have a new voltage distribution.

Step 4: Compare the new voltage distribution solved and the previous one. If they are almost the same, it is the solution we want. If not, delete the previous voltage distribution, adopt the new one, and go back to step 2.

This procedure is also a loop, but we only need one guess in step 1, and the rest of the loop is almost without human intervention. So the computational efficiency is almost determined by the equation itself. In other words, the degree of nonlinearity in equation (4) is the main factor.

## Traditional FEM

In mathematics, FEM is a numerical technique for finding approximate solutions to boundary value problems for partial differential equations. It uses subdivision of a whole problem domain into simpler parts, called finite elements, and variational methods from the calculus of variations to solve the problem by minimizing an associated error function [9], [10].

When we treat material parameters as constants, Eqs. (1) to (3) make up a tradi-

tional FEM problem, and many software programs can solve such a problem. Usually, besides the equations, a traditional FEM problem contains other three parts, namely geometry, materials and boundary conditions. Geometry defines the domain. Materials define the parameters used in the constitutive equation in each domain. Boundary conditions define the constraint conditions on the boundaries.

## 1. Geometry

A typical sample used in PD experiments is a solid sheet insulation that contains a void. Lets assume that the insulation is a cylinder. Its top surface is in contact with the high voltage electrode, while its bottom surface is in contact with the ground electrode. The void is a spheroid in the center of the sheet, as shown in Fig. 2. In typical size, the sheet diameter is  $2R = 20$  mm and the height is  $H = 10$  mm. The void width is  $2a = 12$  mm and the depth is  $2b = 6$  mm.

The problem of the void in the present paper can be treated as a two-dimensional one. A cylindrical coordinate ( $x$ -axis and  $y$ -axis are shown in the figure) is enough, thus reducing calculation complexity.

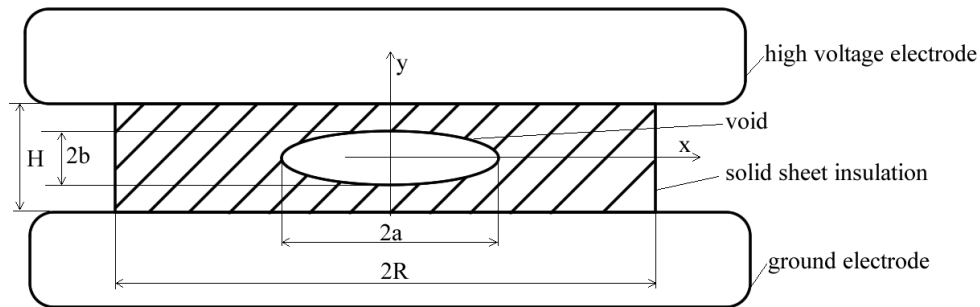

Fig. 2: Cross section of insulation with a void

Tab. 1: Material Parameters

Material	Conductivity (S/m)	Dielectric constant	Breakdown field (V/m)
Insulation	$3.8 \times 10^{-16} \sim 3.8 \times 10^{-14}^*$	$2.3 \epsilon_0^{**}$	$120 \times 10^6$
Void	$5 \times 10^{-14}$	$\epsilon_0$	$3 \times 10^6$

\* Conductivity is influenced by field. High field conduction measurements are given in reference [7].

\*\*  $\epsilon_0$  is permittivity of vacuum.

## 2. Materials

To describe an insulating material in this case, three parameters are needed, namely conductivity, dielectric constant and breakdown field strength. Their values are listed in Tab. 1. The conductivity of insulation is calculated by Eq. (4) based on the voltage distribution in the inner loop, and is treated as a constant during FEM procedure.

It should be pointed out that these parameters are in-

fluenced by temperature. Void material parameters are also influenced by pressure. Dissociation and other chemical changes make the problem more complex. That means all these parameters should be treated as nonlinear variables as the conductivity of insulation [11], [12]. However, in the present paper, in order to simplify, these parameters are selected under standard atmospheric pressure and indoor temperature, and are treated as constants.

## 3. Boundary Conditions

In mathematics, in the field of differential equations, a boundary value problem is a differential equation together with a set of additional constraints, called the boundary conditions. In this case, there are two Dirichlet boundary conditions. One is that the top surface of insulating sample is in high voltage, which is guessed in the outer loop. The other is that the bottom surface is in ground voltage.

### Solving

The present work studies, a typical case, where a solid insulation sheet contains a void. In order to find a solution for the inception voltage, the two loops of the algorithms described above must be applied. The outer loop determines the DIV, while the inner loop computes the electric field from the voltage. The main step of the inner loop is to solve a traditional FEM problem, which contains equations, geometry, materials and boundary conditions.

All these algorithms are programmed in COMSOL Multiphysics, which is a finite element analysis solver and simulation software for various physics and engineering applications, especially coupled phenomena, or multiphysics.

## Results

### 1. DIV in AC Case

DIV in AC case is  $23 \times 10^3$  V, and the electric field distribution under DIV is shown in Fig. 3. In (a), the electric field in the void is higher than that in the insulation. In (b), it is clear that the maximum field appears in the major axis of the ellipsoidal void. This suggests PD are likely to happen in these parts. More decomposition product will be detected there.

### 2. DIV in DC Case

DIV in the DC case is  $160 \times 10^3$  V, and the electric field distribution under DIV is shown in Fig. 4. In (a), the electric field in the void is lower than that in the insulation. In (b), it is clear that the maximum field appears across the minor axis of the ellipsoidal void. This suggests PD are likely to happen in these parts. More decomposition product will be detected there.

### 3. Comparisons and Discussions

DIV in AC and DC cases are very different mainly in two parts.

(1) DIV in DC case is much higher than that in AC case. This suggests that it needs a much higher source in DC PD experiments.

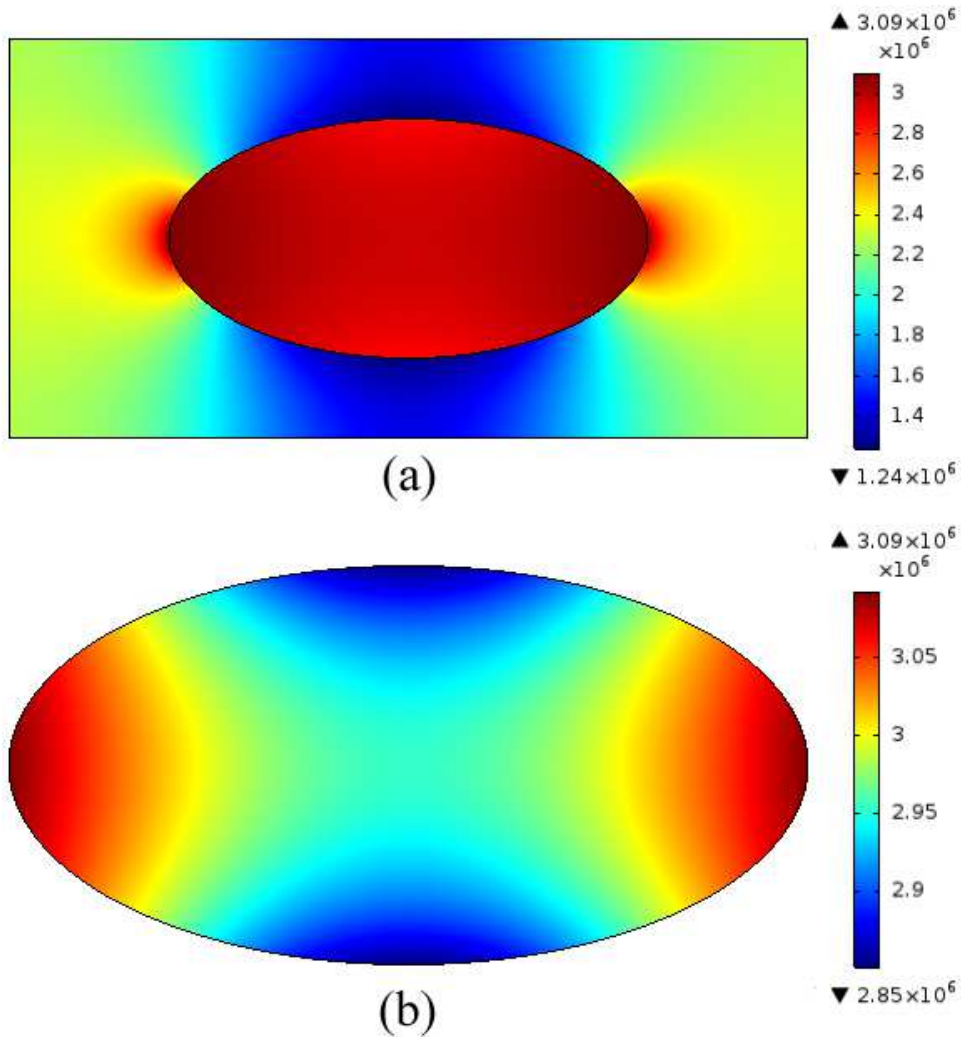

Fig. 3: Electric Field Distribution under IV in AC Case  
 (a) Electric Field Distribution in Sample  
 (b) Electric Field Distribution in Void

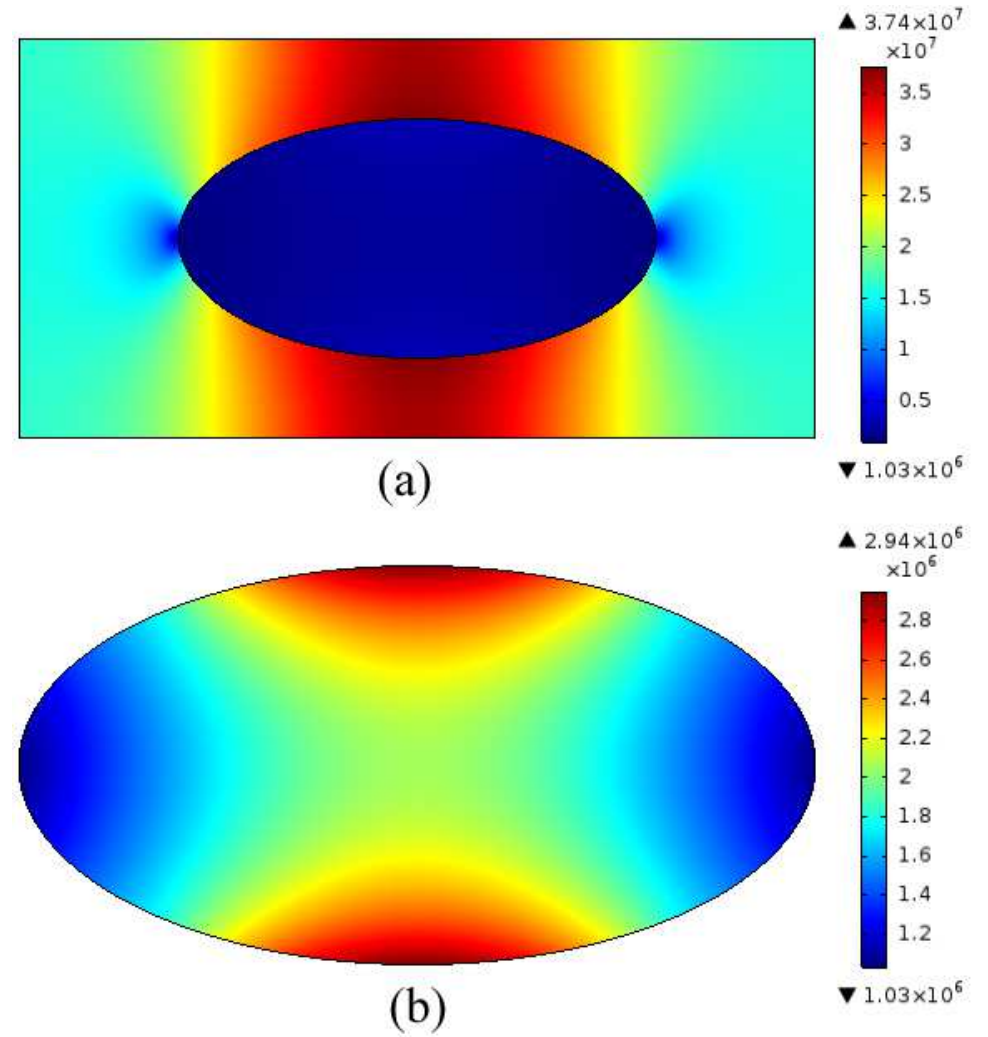

Fig. 4: Electric Field Distribution under IV in DC Case  
 (a) Electric Field Distribution in Sample  
 (b) Electric Field Distribution in Void



DIV in the AC case is  $23 \times 10^3$  V whereas the DIV in the DC case is  $160 \times 10^3$  V. In other words, to observe PD under DC conditions in the same insulation sample, a higher source is needed,

(2) PD happens in totally different parts of the void. PD under AC conditions are likely to happen in the major axis of the ellipsoidal void, whereas PD under DC conditions are likely to happen in the minor axis.

To sum up, when comparing Fig. 3 and Fig. 4, a lower AC voltage can start PD whereas a much higher DC voltage is needed when a DC voltage is applied. Furthermore, the location where PD occurs is different in the two cases.

Theoretically, the DIV calculated in this paper is the real DIV other than the so-called DIV measured by experiments. It is speculated that the real DIV calculated here is lower than the so-called DIV. When the insulating sample is under a voltage between the real DIV and the so-called DIV, PD happens (or at least a charging phenomenon), but the charging amount is not very much. Due to the background interference or the limitations of PD detecting equipment sensitivity, existing techniques and equipment may neglect such PD (or charging phenomena) signals.

Such undetected charging phenomena may cause damage to insulation. So it is reasonable to say that it is possible to have damage below the detected DIV.

#### Conclusions and Prospects

In the present work, iterative method and finite element method (FEM) are used to establish an algorithm with two loops. A typical case is studied, where a solid sheet insulation contains a void. The DIV is calculated by the proposed algorithm with both AC and DC voltage. As the results show, DIV in DC case is much higher than that in AC case. PD under AC conditions are likely to happen in the major axis of the ellipsoidal void, whereas PD under DC conditions are likely to happen in the minor axis.

However, much work and improvements are needed in the future. One possibility is to:

(1) modify the constitutive equations in void based on gas discharge theory, and we may calculate discharge capacity under a different applied voltage, and also,

(2) do some verification experiments. It is proposed that such verification experiments should be performed firstly with voids of considerable size and only afterward with smaller voids.

#### References

- [1] Mason J.H., "Discharges", IEEE Transactions on Electrical Insulation, Vol. 13, No. 4, 1978, pp. 211-238
- [2] Bruning A.M., Kasture D.G., Campbell F.J., Turner N.H., "Effect of cavity current on polymer insulation life", IEEE Transactions on Electrical Insulation, Vol. 26, No. 4, 1991, pp. 826-836
- [3] Danikas M.G., Yin Y., Hu J., "Thoughts on the Possibility of Damage of High-Voltage Electrical Insulation below the so-called Inception Voltage: The Historical Background - Part I.", FunkTechnikPlus # Journal, Issue 7, Year 2, April 2015, pp. 7-18  
[www.otoiser.org/index.php/ftpj/article/view/51](http://www.otoiser.org/index.php/ftpj/article/view/51)
- [4] Bartnikas R., "Partial discharges: Their mechanism, detection and measurement", IEEE Transactions on Dielectrics and Electrical Insulation, Vol. 9, No. 5, 2002, pp. 763-808
- [5] Nosseir A.-R., "Calculation of discharge inception voltage due to the presence of voids in power cables", IEEE Transactions on Electrical Insulation, Vol. 14, No. 2, 1979, pp. 117-120
- [6] Malik N.H., Al-Arainy A.A., Kailani A.M., Khan M.J., "Discharge inception voltages due to voids in power cables", IEEE Transactions on Electrical Insulation, Vol. 22, No. 6, 1987, pp. 787-793
- [7] Zuberi M.U., Masood A., Husain E., Anwar A. "Estimation of partial discharge inception voltages due to voids in solid sheet insulation", Proceedings of the 2013 IEEE Electrical Insulation Conference (EIC), 2-5 June 2013, Ottawa, ON, Canada, 2013, pp. 124-128
- [8] Lan L., Wu J., Yin Y., Li X., Li Z., "Effect of temperature on space charge trapping and conduction in cross-linked polyethylene", IEEE Transactions on Dielectrics and Electrical Insulation, Vol. 21, No. 4, 2014, pp. 1784-1791
- [9] Gallagher T.J., Pearmain A.J., "High voltage: Measurement, testing and design", Editions Wiley and Sons, London, Great Britain, 1983
- [10] Kuffel E., Zaengl W.S., Kuffel J., "High voltage engineering: Fundamentals", Editions Newnes/Butterworth-Heinemann, Oxford, 2000
- [11] Kind D., Kaerner H., "High-voltage insulation technology", Editions Friedr. Vieweg & Son, Braunschweig/

Wiesbaden, Germany, 1985

[12] Kahle M., "Elektrische Isoliertechnik", Editions VEB Verlag Technik, Berlin, Germany, 1988

**Previous Publication in FUNKTECHNIKPLUS # JOURNAL**

"Thoughts on the Possibility of Damage of High-Voltage Electrical Insulation below the so-called Inception Voltage: The Historical Background - Part I",  
Issue 7, Year 2, pp. 7-18

**\* About The Authors**

*Hui Fan*, was born in 1969 and started working in electric power field in 1991, and now he is a senior engineer in State Grid Hebei Electric Power Research Institute, China. His work area covers grid regulation, grid maintenance, power generating technology, electric power equipment manufacturing and so on.

*Jialei Hu*, Issue 7, Year 2, 2015, p. 18

halleyhit@sjtu.edu.cn

*Yi Yin*, Issue 7, Year 2, 2015, p. 18

yiny@sjtu.edu.cn

*Michael Danikas*, Issue 2, Year 1, 2013, p. 39

[ This page Intentionally Left Blank ]

[ This page Intentionally Left Blank ]

In case of any doubt,  
download the genuine papers from  
**[genuine.ftpj.otoiser.org](http://genuine.ftpj.otoiser.org)**

**FRONT COVER VIGNETTE**

A faded synthesis of an anthemion rooted in a meandros

The thirteen-leaf is a symbol for a life tree leaf.  
"Herakles and Kerberos", ca. 530–500 BC,  
by Paseas, the Kerberos Painter,  
Museum of Fine Arts, Boston:  
[www.mfa.org/collections/object/plate-153852](http://www.mfa.org/collections/object/plate-153852)

The simple meandros is a symbol for eternal immortality.  
"Warrior with a phiale", ca. 480–460 BC,  
by Berliner Maler,  
Museo Archeologico Regionale "Antonio Salinas" di Palermo:  
"[http://commons.wikimedia.org/wiki/File:Warrior\\_MAR\\_Palermo\\_NI2134.jpg](http://commons.wikimedia.org/wiki/File:Warrior_MAR_Palermo_NI2134.jpg)"

**ARG NFP AoI**

Antennas Research Group

Not-for-Profit Association of Individuals [\*]

[www.arg.op4.eu](http://www.arg.op4.eu) – [arg@op4.eu](mailto:arg@op4.eu)

Hauptstraße 52, 2831 Scheiblingkirchen, Austria

Telephone: 0 6646311483 – International: 0043 6646311483

\* The Constitution of Greece, Article 12(3) – 2008:

[www.hellenicparliament.gr/en/Vouli-ton-Ellinon/To-Politevma](http://www.hellenicparliament.gr/en/Vouli-ton-Ellinon/To-Politevma)

\* The Hellenic Supreme Court of Civil and Penal Law:

[www.areiospagos.gr/en](http://www.areiospagos.gr/en) – Court Rulings:Civil|A1|511|2008